

Labyrinth (TRIPLE) "TS" Seal  
Standard on SD Housings

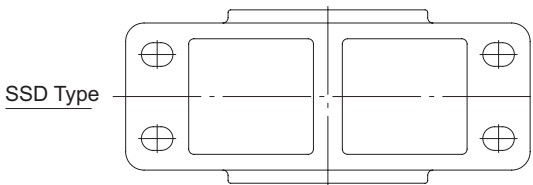

Housing No.	Shaft Dia. d		D H7	d2 H12	d3 H12	A h13	B	F H13
	Metric	Inch						
SD 3134	150	6	280	187	197	170	510	108
SD 3136	160	6 1/2	300	195	205	180	530	116
SD 3138	170	6 3/4	320	217	230	190	560	124
SD 3140	180	7	340	222	237	210	610	132
SD 3144	200	8	370	246	265	220	640	140
SD 3148	220	9	400	265	285	240	700	148
SD 3152	240	9 1/2	440	285	305	260	770	164
SD 3156	260	10	460	307	327	280	790	166
SD 3160	280	11	500	325	345	300	830	180
SD 3164	300		540	345	365	320	880	196
SD 3168	320		580	368	390	340	965	210
SD 3172	340		600	388	408	360	1040	212
SD 3176	360		620	408	428	380	1120	214
SD 3180	380		650	428	448	400	1245	220

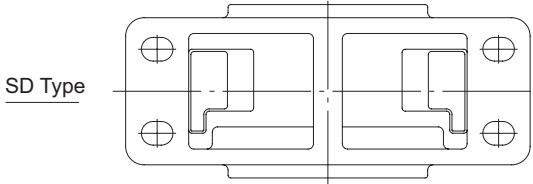
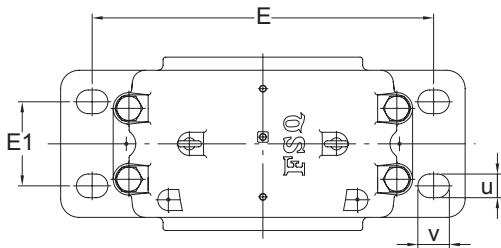
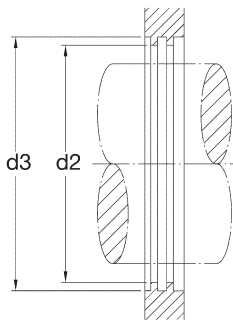
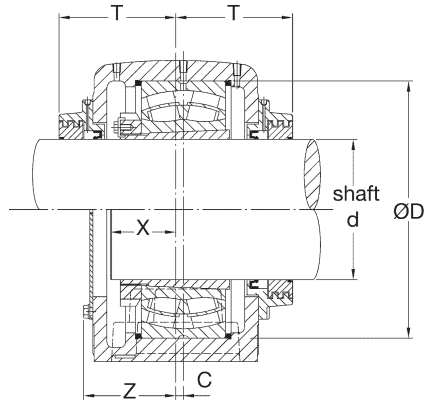

TACONITE TYPE "TAC" Seal

Plummer blocks of series SD 31 TS are used for large spherical roller bearings of Series 231xx CK with adapter sleeves. They are equipped with two labyrinth sealing collars having a push fit on the shaft. A rubber O-ring is fitted between the collar and shaft to ensure rotating together.

Special bosses are provided on the lower half of the housing to allow easy modification for oil lubrication. The bosses can be drilled and tapped to take an oil level gauge and drain plug. An oil circulating system can also be connected. The housings can carry very heavy loads and are designed for heavy duty applications. In severe condition, taconite seal is available to exclude fine abrasive dust and to retain lubricant.

Dimensions mm													Bolt Dia	Spherical Roller Bearing	Adapter Sleeve		Labyrinth Seal		Taconite Seal		Weight	Locating Ring	
E	b	G	H	L	C	E1	X	T	Z	U	V	Seal					End Cover	Seal	End Cover				
															S	Metric	Inch						kg
430	180	70	335	230	14	100	76	154	120	28	35	M24	23134K	H3134	HE3134	TS34	TSA34	TAC34	P34	61.5	280x10	2	
450	190	75	355	240	15	110	81	159	125	30	38	M24	23136K	H3136	HE3136	TS36	TSA36	TAC36	P36	72	300x10	2	
480	210	80	375	260	10	120	86	168	125	35	48	M24	23138K	H3138	HE3138	TS38	TSA38	TAC38	P38	84	320x10	2	
510	230	85	410	280	10	130	91	178	135	35	42	M30	23140K	H3140	HE3140	TS40	TSA40	TAC40	P40	113	340x10	2	
540	240	90	435	290	12	140	96	184	140	36	46	M30	23144K	H3144		TS44	TSA44	TAC44	P44	128	370x10	2	
600	260	95	475	310	12	150	102	194	150	38	46	M30	23148K	H3148		TS48	TSA48	TAC48	P48	166	400x10	2	
650	280	100	515	330	13	160	112	200	160	45	60	M36	23152K	H3152		TS52	TSA52	TAC52	P52	198	440x10	2	
670	280	105	550	320	16	160	115	200	160	45	60	M36	23156K	H3156		TS56	TSA56	TAC56	P56	232	460x10	2	
710	310	110	590	350	22	190	124	213	172	45	64	M36	23160K	H3160		TS60	TSA60	TAC60	P60	279	500x10	2	
750	330	115	630	370	23	200	135	224	187	45	72	M36	23164K	H3164		TS64	TSA64	TAC64	P64	328	540x10	2	
840	380	120	670	390	25	240	155	248	207	52	70	M36	23168K	H3168		TS68	TSA68	TAC68	P68	420	580x10	2	
890	390	130	720	400	22	255	159	254	215	60	77	M48	23172K	H3172		TS72	TSA72	TAC72	P72	584	600x10	2	
980	400	135	750	405	22	255	162	256	220	68	88	M56	23176K	H3176		TS76	TSA76	TAC76	P76	644	620x10	2	
1050	420	140	790	425	22	270	167	267	232	75	96	M64	23180K	H3180		TS80	TSA80	TAC80	P80	740	650x10	2	