

SERIES SDAF 500-HOUSING DIMENSIONS

Housing No. * §	A h13	B	b	G	E		E1	H	L	T	Bolts (No.Req'd)	Wt. in lbs. *	D H7 mm	F mm	d2(H12) mm	d3(H12) mm
	in.	in.	in.	in.	Max. in.	Min. in.	in.	in.	in.	in.						
SDAF 520	4-1/2	15-1/4	6	1-7/8	13-1/8	11-5/8	3-3/8	8-15/16	6-3/4	4-3/4	(4)-3/4	64.8	180	55.8	95.83	114.88
SDAF 522	4-15/16	16-1-2	6-3/4	2-1/8	14-1/2	12-5/8	4	9-7/8	7-1/4	4-7/8	(4)-7/8	96.1	200	62.8	110.11	129.16
SDAF 524	5-1/4	16-1/2	6-7/8	2-1/4	14-1/2	13-1/4	4-1/8	10-1/2	7-3/8	4-15/16	(4)-7/8	107.3	215	67.8	113.8	132.84
SDAF 526	6	18-3/8	7-1/2	2-3/8	16	14-5/8	4-12	11-7/8	8	5-1/4	(4)-1	147.2	230	73.8	121.74	140.8
SDAF 528	6	20-1/8	7-1/2	2-3/8	17-1/8	16	4-1/2	12-1/6	7-15/16	5-5/16	(4)-1 1/8	131.4	250	77.8	132.84	151.9
SDAF 530	6-5/16	21-1/4	7-7/8	2-1/2	18-1/4	17	4-3/4	12-13/16	8-3/8	5-7/16	(4)-1 1/8	157.1	270	82.8	142.88	161.93
SDAF 532	6-11/16	22	8-1/4	2-1/2	19-1/4	17-3/8	5	13-11/16	8-3/4	5-5/8	(4)-1 1/8	187.1	290	89.8	146.05	171.45
SDAF 534	7-1/16	24-3/4	9	2-1/2	21-5/8	19-3/8	5-1/2	14-1/4	9-5/8	5-15/16	(4)-1 1/4	212.3	310	95.8	161.11	186.51
SDAF 536	7-1/2	26-3/4	9-3/8	2-3/4	23-5/8	20-7/8	5-7/8	15-1/2	10	6-1/8	(4)-1 1/4	292.1	320	95.8	172.21	197.61
SDAF 538	7-7/8	27-5/8	10	3	23-1/2	21-1/2	6-1/4	16-1/4	10-5/8	6-1/2	(4)-1 3/8	338.4	340	101.8	188.29	210.91
SDAF 540	8-1/4	28-3/4	10-1/2	3-1/4	25	23	6-3/4	17-1/8	11-1/8	6-7/8	(4)-1 3/8	343.7	360	107.8	196.8	219.42
SDAF 544	9-1/2	32	11-1/4	3-1/2	27-7/8	25-5/8	7-1/4	19-1/4	11-7/8	7-1/8	(4)-1 1/2	513.0	400	117.8	216.81	239.43

SERIES SDAF 600-HOUSING DIMENSIONS

Housing No. * §	A h13	B	b	G	E		E1	H	L	T	Bolts (No.Req'd)	Wt. in lbs. *	D H7 mm	F mm	d2(H12) mm	d3(H12) mm
	in.	in.	in.	in.	Max. in.	Min. in.	in.	in.	in.	in.						
SDAF 616	4-1/4	14-1/4	5-1/2	1-3/4	12-5/8	10-5/8	3-1/4	8-1/4	6-3/8	4-1/2	(4)-5/8	49.3	170	67.8	77.34	90.48
SDAF 617	4-1/2	15-1/4	6	1-7/8	13-1/8	11-5/8	3-3/8	8-15/16	6-3/4	4-11/16	(4)-3/4	67.2	180	69.8	81.03	100.08
SDAF 618	5-3/4	15-1/2	6-1/8	2	13-1/2	12	3-5/8	9-7/16	6-7/8	4-13/16	(4)-3/4	72.0	190	73.8	91.06	110.11
SDAF 620	5-1/4	16-1/2	6-7/8	2-1/4	14-1/2	13-1/4	4-1/8	10-12	7-3/8	5-1/16	(4)-7/8	110.3	215	82.8	95.83	114.88
SDAF 622	6	18-3/8	7-1/2	2-3/8	16	14-5/8	4-1/2	11-7/8	8	5-1/4	(4)-1	147.1	240	89.8	110.11	129.16
SDAF 624	6-5/16	21-1/4	7-7/8	2-1/2	18-1/4	17	4-3/4	12-13/16	8-3/8	5-7/16	(4)-1 1/8	171.7	260	95.8	113.8	132.84
SDAF 626	6-11/16	22	8-1/4	2-1/2	19-1/4	17-3/8	5	13-11/16	8-3/4	5-5/8	(4)-1 1/8	193.5	280	102.8	121.74	140.8
SDAF 628	7-1/16	24-3/4	9	2-1/2	21-5/8	19-3/8	5-1/2	14-1/4	9-3/8	6	(4)-1 1/4	228.3	300	111.8	132.84	151.9
SDAF 630	7-1/2	26-3/4	9-3/8	2-3/4	23-5/8	20-7/8	5-7/8	15-3/16	9-3/4	6-1/8	(4)-1 1/4	300.2	320	117.8	142.88	161.93
SDAF 632	7-7/8	27-5/8	10	3	23-1/2	21-1/2	6-1/4	16-1/4	10-5/8	6-1/2	(4)-1 3/8	355.1	340	123.8	148.58	171.2
SDAF 634	8-1/4	28-3/4	10-1/2	3-1/4	25	23	6-3/4	17-1/8	11-1/8	6-3/4	(4)-1 3/8	393.8	360	129.8	161.3	183.92
SDAF 636	8-7/8	30-1/2	10-3/4	3-1/4	26-3/8	24-1/8	6-7/8	17-15/16	11-3/8	6-7/8	(4)-1 1/2	404.7	380	135.8	172.72	195.34
SDAF 638	9-1/2	32	11-1/4	3-1/2	27-7/8	25-5/8	7-1/4	19-1/4	11-7/8	7-1/8	(4)-1 1/2	484.4	400	141.8	188.29	210.91
SDAF 640	9-7/8	33-1/2	11-3/4	3-1/2	29-1/4	26-5/8	7-5/8	19-15/16	12-3/8	7-1/2	(4)-1 5/8	564.1	420	147.8	196.8	219.42

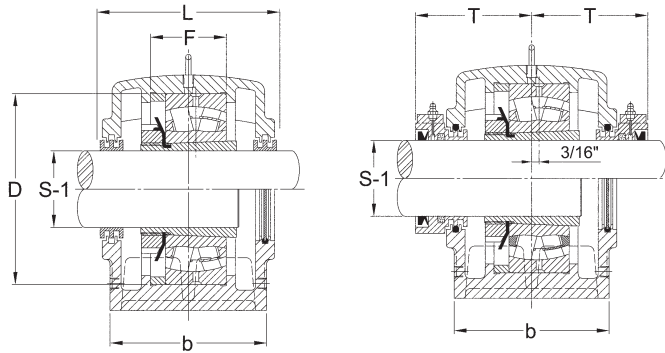

TACONITE Seal OPTION

NOTES:

- ★ Basic housing does not include bearing and accessories. The weight is subject to change.
- § For float unit application, order 1-housing, 2-labyrinth seals, 1-adapter sleeve.
For fixed unit application, add 1-stabilizing ring to the above.

SERIES SDAF 225-PILLOW BLOCK PART NUMBERS

Shaft Diameter S-1 in.	Complete Pillow Block Number	Pillow Block Housing Only	Bearing Number	Adapter Sleeve	Lab. Seal Ring (2 Required)	Stabilizing Ring (1 required)	End Plug (EPR)
3-7/16	SDAF 22520	SDAF 520	22220 K	SNW 20	LER 75	SR-20-17	11
3-15/16	SDAF 22522	SDAF 522	22222 K	SNW 22	LER 93	SR-22-19	13
4-3/16	SDAF 22524	SDAF 524	22224 K	SNW 24	LER 113	SR-24-20	14
4-7/16	SDAF 22526	SDAF 526	22226 K	SNW 26	LER 117	SR-26- 0	15
4-15/16	SDAF 22528	SDAF 528	22228 K	SNW 28	LER 122	SR-28- 0	27
5-3/16	SDAF 22530	SDAF 530	22230 K	SNW 30	LER 125	SR-30- 0	16
5-7/16	SDAF 22532	SDAF 532	22232 K	SNW 32	LER 130	SR-32- 0	16
5-15/16	SDAF 22534	SDAF 534	22234 K	SNW 34	LER 140	SR-34- 0	18
6-7/16	SDAF 22536	SDAF 536	22236 K	SNW 36	LER 148	SR-36-30	19
6-15/16	SDAF 22538	SDAF 538	22238 K	SNW 38	LER 224	SR-38-32	21
7-3/16	SDAF 22540	SDAF 540	22240 K	SNW 40	LER 228	SR-40-34	22
7-15/16	SDAF 22544	SDAF 544	22244 K	SNW 44	LER 236	SR-44-38	24

SERIES SDAF 226-PILLOW BLOCK PART NUMBERS

Shaft Diameter S-1 in.	Complete Pillow Block Number	Pillow Block Housing Only	Bearing Number	Adapter sleeve	Lab. Seal Ring (2 Required)	Stabilizing Ring (1 required)	End Plug (EPR)
2-11/16	SDAF 22616	SDAF 616	22316 K	SNW 116	LER 44	SR-19-16	8
2-15/16	SDAF 22617	SDAF 617	22317 K	SNW 117	LER 59	SR-20-17	10
3-3/16	SDAF 22618	SDAF 618	22318 K	SNW 118	LER 69	SR-21-18	11
3-7/16	SDAF 22620	SDAF 620	22320 K	SNW 120	LER 75	SR-24-20	11
3-15/16	SDAF 22622	SDAF 622	22322 K	SNW 122	LER 93	SR- 0-22	13
4-3/16	SDAF 22624	SDAF 624	22324 K	SNW 124	LER 113	SR- 0-24	14
4-7/16	SDAF 22626	SDAF 626	22326 K	SNW 126	LER 117	SR- 0-26	15
4-15/16	SDAF 22628	SDAF 628	22328 K	SNW 128	LER 122	SR- 0-28	27
5-3/16	SDAF 22630	SDAF 630	22330 K	SNW 130	LER 125	SR-36-30	16
5-7/16	SDAF 22632	SDAF 632	22332 K	SNW 132	LER 211	SR-38-32	17
5-15/16	SDAF 22634	SDAF 634	22334 K	SNW 134	LER 215	SR-40-34	19
6-7/16	SDAF 22636	SDAF 636	22336 K	SNW 136	LER 220	SR- 0-36	26
6-15/16	SDAF 22638	SDAF 638	22338 K	SNW 138	LER 224	SR-44-38	21
7-3/16	SDAF 22640	SDAF 640	22340 K	SNW 140	LER 228	SR- 0-40	22