

**Cast Iron Flange Cartridge Units**  
Set Screw Locking

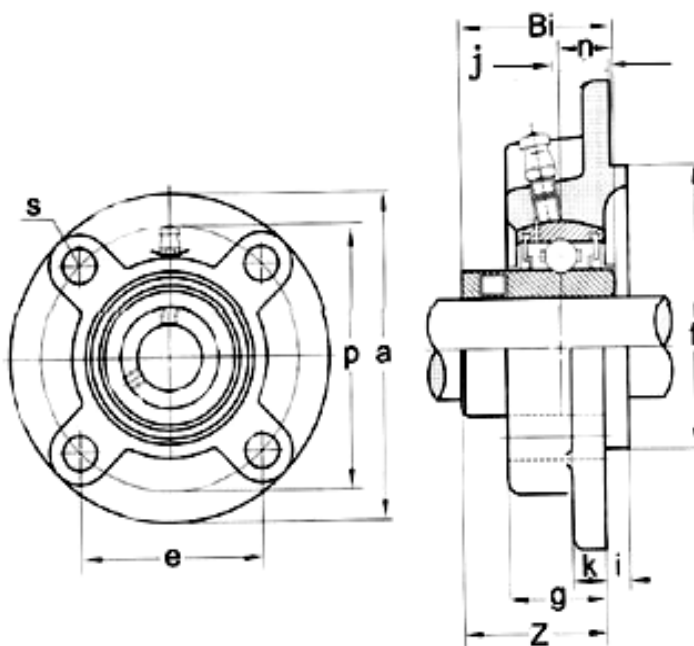

Unit No.	Shaft Dia.	Dimensions (mm/inch)											Bearing No.	Housing No.	
	mm	a	p	e	i	s	j	k	g	f	Z	Bi			n
UCFC 204	20	100	78	55.1	10	12	5	7	20.5	62	28.3	31	12.7	UC 204	FC 204
UCFC 205	25	115	90	63.6	10	12	6	7	21	70	29.7	34.1	14.3	UC 205	FC 205
UCFC 206	30	125	100	70.7	10	12	8	8	23	80	32.2	38.1	15.9	UC 206	FC 206
UCFC 207	35	135	110	77.8	11	14	8	9	26	90	36.4	42.9	17.5	UC 207	FC 207
UCFC 208	40	145	120	84.8	11	14	10	9	26	100	41.2	49.2	19	UC 208	FC 208
UCFC 209	45	160	132	93.3	10	16	12	14	26	105	40.2	49.2	19	UC 209	FC 209
UCFC 210	50	165	138	97.6	10	16	12	14	28	110	42.6	51.6	19	UC 210	FC 210
UCFC 211	55	185	150	106.1	13	19	12	15	31	125	46.4	55.6	22.2	UC 211	FC 211
UCFC 212	60	195	160	113.1	17	19	12	15	36	135	56.7	65.1	25.4	UC 212	FC 212
UCFC 213	65	205	170	120.2	16	19	14	15	36	145	55.7	65.1	25.4	UC 213	FC 213